

# DIAMOND

## Fiber Optic Components

### CABLE ASSEMBLIES AND ADAPTERS

The Mini-AVIM connector has been developed after market request of a smaller and lighter version of our acclaimed AVIM connector for harsh environment, especially space applications.

The Mini-AVIM combines two leading edge technologies: the AVIM MIL-style ratchet system and the base construction of Diamond Micro Interface (DMI) connector.

Commercial Off-The-Shelf (COTS) availability and economy backed by component availability from stock and quick turnaround of terminations and assemblies.

The Mini-AVIM is aligned precisely in rotation and therefore it can be used for both standard SM and MM fibers, as well as for PM technologies and multi-fiber ferrules.

Our Power Solution (PS) technology can also be applied to this connector.

Harsh environment applications will range from Space to underwater, applying to mobile, avionics, shipboard, oil downhole, etc.

### FEATURES

- ▶ Compact, small and lightweight
- ▶ Low loss thanks to Diamond Active Core Alignment (A.C.A.)
- ▶ High return loss thanks to Diamond polishing technique and A.C.A.
- ▶ Miniaturized MIL-style ratchet system with high vibration/shock resistance
- ▶ AllTitanium – ZrO2 material for ultra low CTE mismatch

### STANDARDS

- ▶ ESCC 2263010 Follows ESA standard for space

The Mini-AVIM is now following an ESTEC Qualification program, due to be completed by the end of 2011.

### AVAILABLE AS

- ▶ Terminated connector (commercial, enhanced or space grades)
- ▶ Connector set (to be terminated with Diamond special equipment)
- ▶ Multi-fiber custom connector set and assembled terminations
- ▶ Mating adapters (commercial, enhanced, space grades)

### Mini-AVIM

SINGLE MODE	PC/APC
MULTIMODE	PC
PM	PC/APC
PS	APC4°



### MINI-AVIM CONNECTOR DIMENSIONS

Connectors for 900um buffer coatings (or loose tube) up to 1.2mm cable

Available types: **Mini-AVIM (PC, APC, PM, PS)**

Material: According to part list

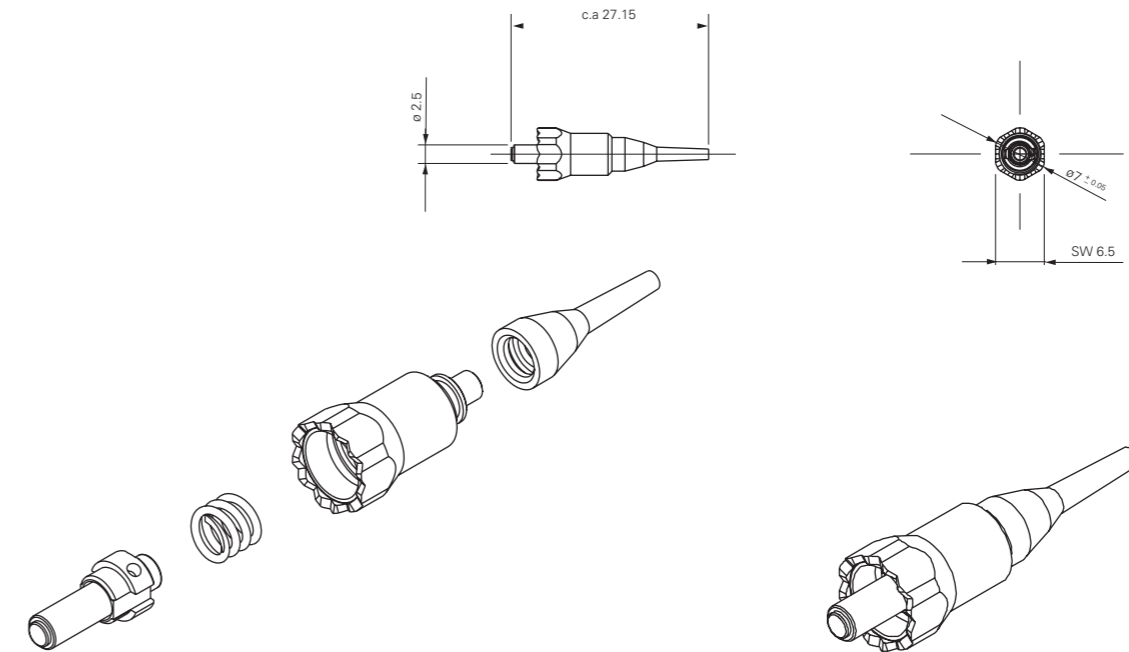

### BILL OF MATERIAL - BOM

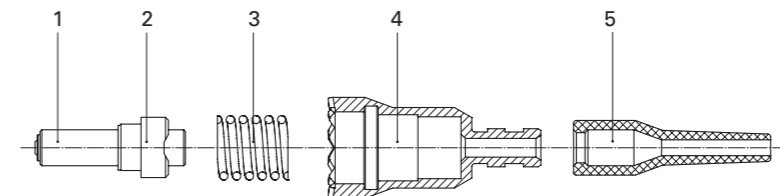

POS.	DESCRIPTION	MATERIAL		WEIGHT (gr.)
		NAME	NORMS	
1	Ferrule	Ceramic-Titanium	ZrO2, UNS R50250	0.27
2	DMI ring	Titanium	UNS R56400	0.09
3	Spring	Stainless steel	1.4310	0.12
4	Outside shell	Titanium	UNS R56400	0.58
5	Vacuum backed boot	Thermoplastic Elastomer TCP-ET	Hytrel 8068 <sup>1</sup>	0.06
<b>Total</b>				<b>1.12</b>

<sup>1</sup> Vacuum baked, 24h at 110°C to 125°C and 10<sup>-3</sup> Torr

**NOTE** Diamond's standard **boot** colors are as follows: Black for MM and SM PC, and green for SM APC.

### ORDER INFORMATION

When ordering mating adapters, please refer to the part numbers provided in the enclosed P/N list. When ordering pigtails or cable assemblies, please refer to the **connector type description** in the Available types section, and fill in the Simplex, Duplex, Multiple fiber Assemblies order form according to **those** denominations.



DIAMOND SA • Via dei Patrizi 5 • CH-6616 Losone • Switzerland  
Tel. +41 91 785 45 45 • Fax +41 91 785 45 00 • e-mail info@diamond-fo.com

www.diamond-fo.com

Specifications subject to change without notice

1951130 01\_10

**SPECIFICATIONS**

MINI-AVIM - TECHNICAL CHARACTERISTICS					
	COMMERCIAL GRADE			ENHANCED/SPACE GRADE	
Mechanical Performances		IL value using ITU-T G.652C	Standards		Standards
Mating durability	250 mating cycles	≤ 0.2dB	IEC 61300-2-2	250 mating cycles	ESCC 2263010
Shock, Impact	5 drops 1.5m, l=2m	≤ 0.2dB	IEC 61300-2-12 method A	Half-sine shock 75g for 11ms	ESCC 2263010
Vibration	1oct/min, 20g@60Hz-2kHz	≤ 0.2dB	IEC 61300-2-1	35.4g random 8min per axis	ESCC 2263010
Environment Characteristics					
Operation Temperature	-40°C to + 80°C, 1°C/min, 1h dwell, 20 cycles	≤ 0.3dB	IEC 61300-2-22	-55°C to + 125°C, 3°/min, 15min dwell, 100 cycles	ESCC 2263010
Non-Operation Temperature	-55°C to + 125°C	≤ 0.3dB		-55°C to + 125°C	ESCC 2263010
Temperature Shock	n.a.	n.a.		TBD	ESCC 2263010
Cold	168h, -40°C	≤ 0.2dB	IEC 61300-2-17	2000h, -150°C	ESCC 2263010
Dry Heat	168h, 85°C	≤ 0.2dB	IEC 61300-2-18	2000h, +125°C	ESCC 2263010
Damp Heat	168h, 40°C, 95%	≤ 0.1dB	IEC 61300-2-26	TBD	ESCC 2263010
Outgassing				1% max T.M.L.; 0.1% C.V.VM	ESCC 2263010
Rapid Depressurisation	n.a.	n.a.		Atmospheric to 50mbar in 5s	ESCC 2263010
Optical Characteristics					
	For ITU-T G.652C fiber			For ITU-T G.652C fiber	
Insertion Loss, IL	0.15dB typical, 0.4dB max		IEC 61300-3-4 method B	0.2dB typical, 0.4dB max	
Return Loss, RL	PC >40dB; APC >75dB		IEC 61300-3-6 method OLCR	PC >40dB; APC >75dB	
Extinction Ratio, ER	ER>23dB, ER typical 28dB*		Similar to IEC 61300-3-40	ER>23dB, ER typical 25dB	
Cable related Characteristics					
	Diamond Homologated cables				
Torsion	2N, 25 cycles 180°	≤ 0.2dB	IEC 61300-2-5	n.a.	
Static side load	0.2N, 90°, 5min	≤ 0.2dB	IEC 61300-2-42		
Fiber Retention	5N, 1min	≤ 0.2dB	IEC 61300-2-4		
Bending moment	10N, l=25mm	≤ 0.2dB	IEC 61300-2-7		

\* with Corning PM1550nm fiber

ESCC (ESA Space Component Coordination)

**MINI-AVIM MOUNTING TOOL**

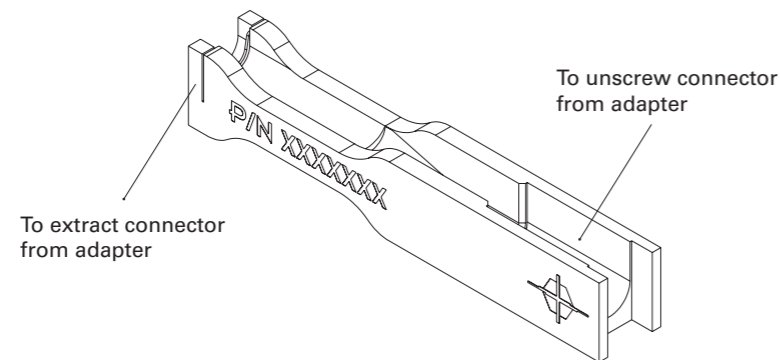

**MINI-AVIM ADAPTER AND DIMENSIONS**

Available types:

Square flange adapter for wall mount

Material:

According to part list

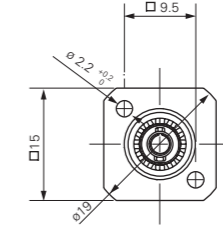
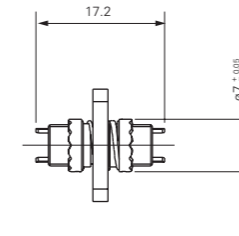
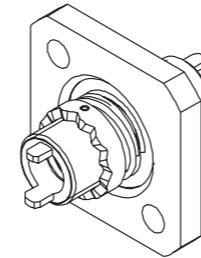

CUTOUT DIMENSIONS

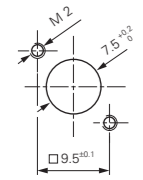

**BILL OF MATERIAL - BOM**

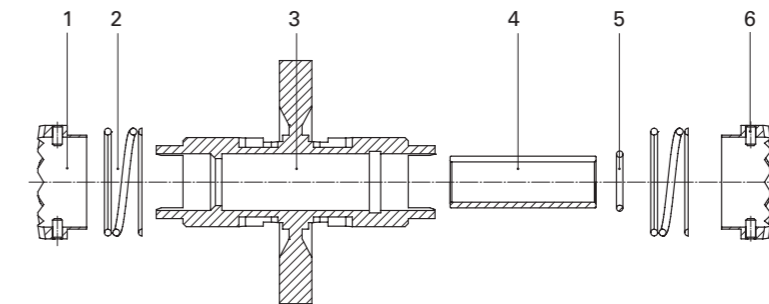

POS.	DESCRIPTION	MATERIAL		WEIGHT (gr.)
		NAME	NORMS	
1	Anti-rotation ring (2x)	Titanium	UNS R56400	0.20
2	Anti-rotation spring (2x)	Stainless steel	1.4310	0.07
3	Main body	Titanium	UNS R56400	2.12
4	Split sleeve	Zirconia	ZrO2	0.16
5	Clip for split sleeve	Stainless steel	1.4310	0.01
6	Pin for Anti-rotation ring (4x)	Stainless steel	1.4305	0.01
<b>Total</b>				<b>2.57</b>