

DIAMOND

Fiber Optic Components

PSm family

CABLE ASSEMBLIES AND ADAPTERS

Multimode fibers are increasingly being used to transmit high power and connectors are incorporating a modular design to help eliminate the need for a splice.

Diamond has developed the **E-2000® PSm** and products utilizing our optical interface PSm technology for use with these fibers and applications. Our Power Solution products are designed to work with all optical fiber destined for higher power applications. For multimode fibers in particular, our **PSm** technology has been developed to guarantee high power transmission targeting mainly, but not limited to, pump lasers integration. The DIAMOND PSm mating adapter use a floating Tungsten carbide sleeve improving power resistance of the assembly.

Tungsten carbide thermal dissipation is ca 50x higher than that of the ceramic and ca 5x that of the stainless steel. The hardness, precision, thermal conductivity and wear resistance of Tungsten carbide make it an ideal material to use for high power application.

DIAMOND is a specialist of hard material and is using tungsten carbide (WC) for 30 years in ferrules and sleeves.

BENEFITS

- ▶ Resistant to high power
- ▶ Low Insertion loss
- ▶ Easy thermal management

OPTICAL SPECIFICATIONS

	MM105 PC 0°	MM200 PC 0°	UNITS	TEST CONDITIONS
Numerical Aperture, NA	0.22			
Core / Cladding	105 / 125	200 / 240	microns	
Insertion Loss (IL)	≤ 0.2 (0.1 typ)*	≤ 0.2 (0.1 typ)**	dB	IEC 61300-3-4
Optical power handling	100***		W	IEC 61300-2-14
Service life	100		mate/demate	IEC 61300-2-2

* With launch condition from light source: conditioning patchcord, 300m of 100/140 fiber and 30m of 105/125 fiber

** With launch condition from light source: conditioning patchcord, 300m of 100/140 fiber and 30m of 200/220 fiber

*** Tested with CW laser. Requires cooling of the mating adapter basement to 20°C. Thermal power to dissipate: max. 5 W

ENVIRONMENTAL CONDITIONS

MEASUREMENT / TEST	PARAMETERS	METHOD
Change of temperature	-40°C / +85°C / 1 h dwell / 12 cycles	IEC 61300-2-22
Cold	-40°C / 96 h	IEC 61300-2-17
Dry heat	+85°C / 96 h	IEC 61300-2-18
Damp heat, cyclic	+25°C / +55°C / 95% r.h. / 6 cycles	IEC 61300-2-46
Operating temperature	-40°C / +85°C*	
Storage temperature	-40°C / +90°C	

* Requires cooling of the mating adapter basement to 20°C.

NOTE For safety, cleaning and handling information, please refer to the user manual art. n. 1902330.

E-2000® PSm

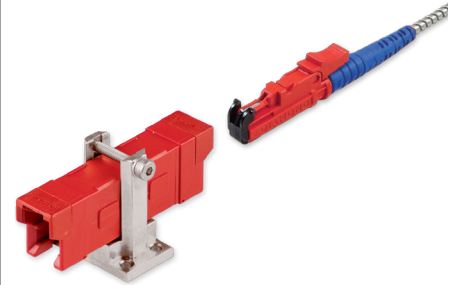

E-2000® PSm



DIAMOND SA | Via dei Patrizi 5 | CH-6616 Losone - Switzerland
Tel. +41 58 307 45 45 | e-mail info@diamond-fo.com

www.diamond-fo.com

Specifications subject to change
without notice

BDD 1951642 07_20

AVAILABLE AS

- ▶ Pigtail and patchcord on the following mechanical interfaces:
 - E-2000® PSm
 - Optional stainless steel furcation tube 2.9mm (E-2000®)
- ▶ Mating adapter
 - E-2000® with hard metal high precision sleeve (for thermal dissipation).
 - Thermal socket

STANDARDS

The Optical Interface is only available on E-2000® connector mechanical interface.

- ▶ TIA/EIA 604-16 Fiber Optic Intermateability standard - Type LSH
- ▶ IEC 61754-15 Fiber optic connector interfaces – Part 15: Type LSH connector family

E-2000® PSm CONNECTOR TYPES AND DIMENSIONS

E-2000® PSm connectors 3 mm boot style

- Available types: **E-2000® PSm PC**
- Ferrule material: Zirconia/metal insert
- External parts: Plastic (red body and thumb latch; blue boot)

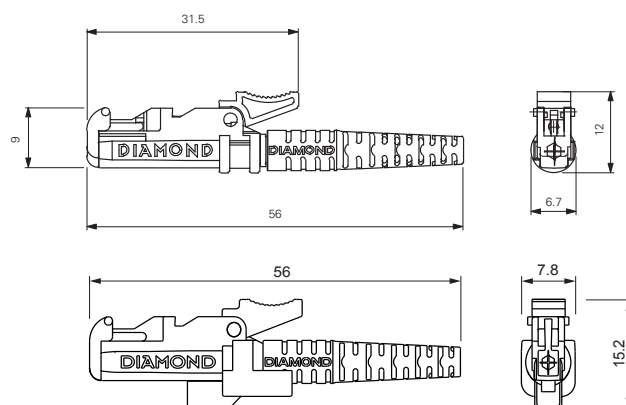

ADAPTER TYPE AND DIMENSIONS

- External parts: Plastic (red body and frames)
- Base mount: Ni-plated Cu

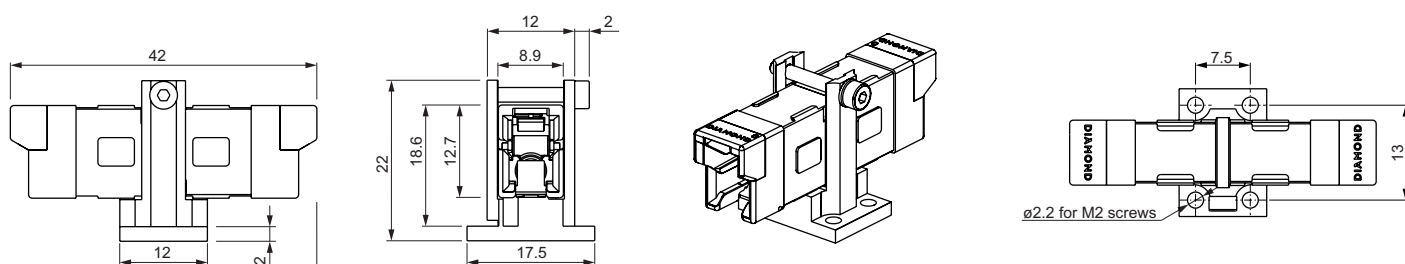

NOTE Color or mechanical keying thumb-latches and frame available. Please refer to the E-2000® standard datasheet.

ORDER INFORMATION

To order your connectors using this technology, please specify

- The connector type (E-2000® PSm MM105)
 - For the E-2000® connector
- Example: Patchcord L=2m, 0.9mm elastomeric tube, 2x E-2000® PSm MM105