



DMI (DIAMOND Micro Interface)

Detachable miniature optical interface for multiple usage



Outline



- Product Description
- Features and Benefits
- Optical Interface Specifications
 - SM and MM
 - VIS-NIR
 - PM
 - PS
 - PM-PS
 - PSm
- System Integration and Flexibility
- Mounting Instructions



The Connector



- Extremely compact FO-interface based with Standard $\varnothing 2.5$ mm Ferrule Technology
- “Clip-on” mount for easy assembly and mechanical stability



1:1 SCALE



Fiber management solution

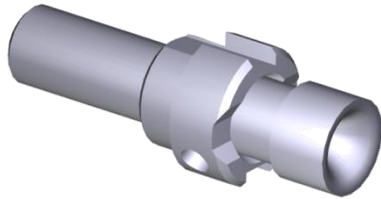

- Rear tube for short radius fiber exit.
(cannot be installed on standard DMI mating adapter and clip; requires a customized fixation)

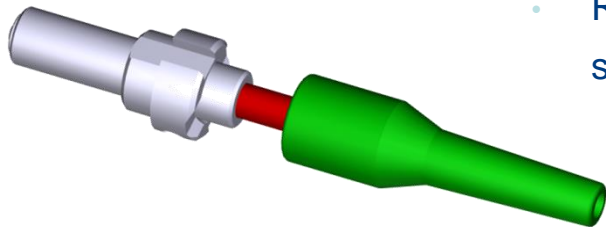

- Rear tube with boot fixing (can be installed on standard DMI mating adapter and clip)



Features and Benefits

- Minimum space requirement
 - allows for high density, low profile connections
- Bi-component Titanium-Zirconia ferrule
 - very good temperature behavior, allows for ultra polishing
 - Adapted to PSm high-power solutions for pump lasers
 - ultra low IL and RL, small core fiber for ultimate performance
 - PS and PM-PS low IL with modified ACA
 - PSm low IL with modified ACA
 - High PER values for PM and PM-PS applications
- Active Core Alignment (ACA)
 - Improved optical performance, extremely good repeatability
 - Best for PM and PM-PS solutions
- Active Polarization orientation (APO)
- Asymmetric high precision keys
 - Easy finger or tool assisted handling
 - for high reliability handling
- Clip-on mating adapter
- Tooling available

Specifications for standard version



STANDARD	MULTIMODE 0° PC	SINGLE MODE 0° PC	SINGLE MODE 8° APC	UNITS	TEST CONDITIONS
Insertion Loss (IL) Random	typ. 0.2 max. 0.4	typ. 0.15 max. 0.4	typ. 0.15 max. 0.4	dB	IEC 61300-3-4; $\lambda = 1300/1550\text{nm}$
Return Loss (RL)	min. 40	min. 50	min. 70*	dB	IEC 61300-3-6; $\lambda = 1300/1550\text{nm}$
Low IL Version					
Insertion Loss (IL) Random	-	typ. 0.1 max. 0.25	typ. 0.1 max. 0.25	dB	IEC 61300-3-4; $\lambda = 1300/1550\text{nm}$
Return Loss (RL)	-	min. 50	min. 75*	dB	IEC 61300-3-6; $\lambda = 1300/1550\text{nm}$
Repeatability of IL	max. ± 0.05			dB	IEC 61300-2-2; $\lambda = 1300/1550\text{nm}$
Service life	500 mate/demate cycles				
Operating temperature	-25/+70**			°C	

* Measured with high precision reflectometer

** May be further limited by fiber specifications

DMI for VIS-NIR version

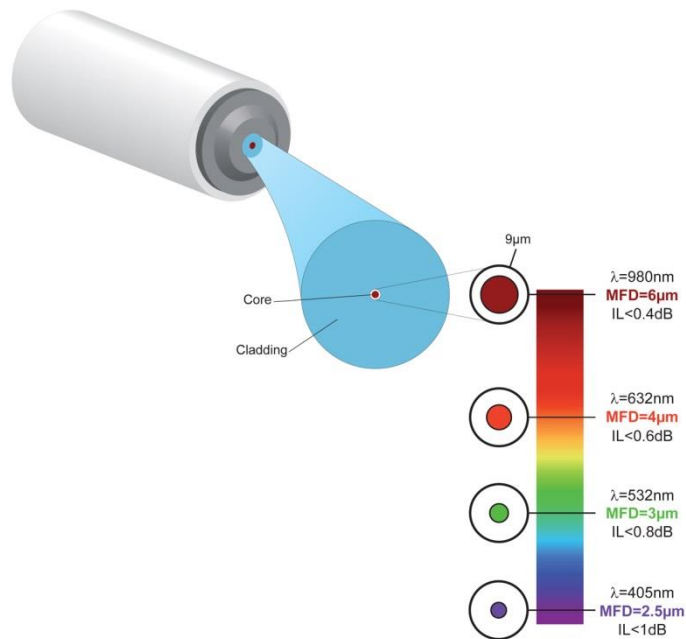

- Applications using non-telecom wavelength single mode and PM fibers exist in various applications, such as Biomedical, Measurement instruments, Laser source delivery, and sensing.
- DIAMOND offers the DMI **VIS/NIR** optical interface for low wavelengths (405-1060nm) and small core fibers.
- Diamond Active Core Alignment (ACA)
 - ➔ Extremely low lateral offset for Low Insertion loss
 - ➔ Ultra high polish for High return loss

Specifications for VIS-NIR version



WAVELENGTH (nm)	MFD (μm)	IL random 97% (dB)	IL max (dB)	RL	
				PC (dB)	APC (dB)
1060 - 980	6.6	0.2	0.3	45	60*
830 - 780	5.2	0.3	0.4	40	60*
635	4.4	0.4	0.6	40	60*
532 - 460	3.5	0.5	0.8	35	60*
405	2.9	0.6	1	35	50*
TEST CONDITIONS		IEC 61300-3-34 Random mating	IEC 61300-3-4	IEC 61300-3-6 OCWR method	

NOTE - The above values are intended for E-2000™ connector. Other connector mechanical interface display higher values. Please contact Diamond for values on your specific connector type.

- NA 0.12
- The Mode Field Diameter (MFD) of a SM or PM fiber, depends on the ratio between the following two parameters: Wavelength, and Numerical Aperture. $MFD=f(\lambda/NA)$.

* Limited by test conditions

DMI Polarization Maintaining (PM) version

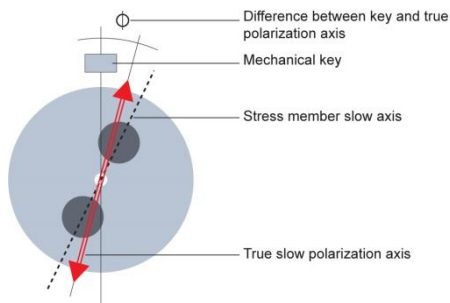

DIAMOND provided high-quality solutions to polarization maintaining (PM) and polarizing (PZ) fiber optical interfaces for optimal control of the signal's polarization state. Low insertion losses (IL) combined with high polarization extinction ratios (PER) and higher return losses (RL) are achieved over very broad spectral ranges due to a combination of accurate optical and mechanical design.

■ Applications:

- Biomedicine
- Spectroscopy
- Metrology
- Sensorics
- Telecommunications
- Laser technology
- Surveillance & Security
- Lithography

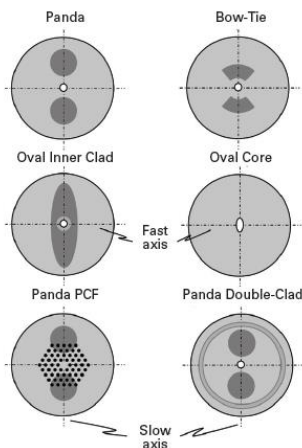

Specifications for PM version



WAVELENGTH (nm)	Angular Error ϕ	IL (dB)		PER (dB)		RL (dB)	
		Typ	97% (TBC)	Typ	Min (TBC)	PC 0°	APC 8°
1625 - 1550 - 1310	< $\pm 2^\circ$	0.18	0.35	30	27	50*	70*
1060 - 980		0.23	0.45	30	26	50	60*
830 - 780		0.28	0.55	28	25	40	60**
680 - 635		0.33	0.65	28	25	40	60**
532 - 460		0.43	0.85	27	24	35	60**
405		0.78	1.25	23	21	35	60**
TEST CONDITIONS		IEC 61300-3-34 Random mating		IEC 61300-3-40 Low coherence		IEC 61300-3-6 *OLCR method <OCWR method **Limited by test conditions	
Lifetime	500 mate/demate cycles						

- Optical values based upon high-quality Panda and Bow-Tie fibers qualified by Diamond (fiber's NA 0.12 \pm 0.02).

DMI Power Solution (**PS**) version

DIAMOND offers the **PS** optical interface, which expands the MFD of a SM fiber by splicing a GRIN lens at the extremity. The MFD at the end of the connector is thus expanded by a factor of 4, increasing the contact surface by a factor of about 16. As a result, the heat issues decrease, but cleanliness of the connectors and mating adapters is still important.

SPECIFICATIONS

CONNECTOR TYPE	WAVELENGTH (nm)	IL (dB) AGAINST REFERENCE		RL AGAINST REFERENCE		
		Typ.	Max.	Connected		Unmated
				PC 0°	APC 4°	APC 4°
DMI PS	1625 - 1550 - 1310	0.2	0.4	45	75	50
	1060 - 980	0.3	0.6	35*	60*	
TEST CONDITIONS		IEC 61300-3-4		IEC 61300-3-6 OLCR method / *OCWR method		

NOTE - The APC version has an angle of 4° instead of 8°, due to a trade-off between Insertion Loss and Return loss values.

Diamond PS collimated technology

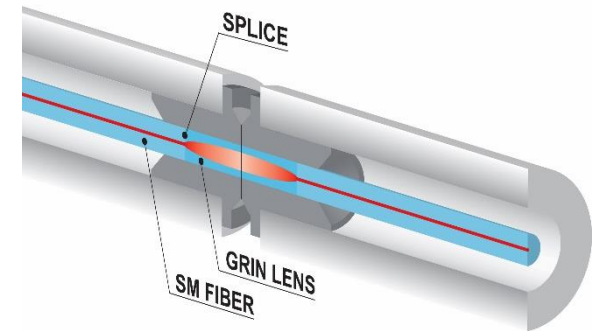

DMI for PM-PS version

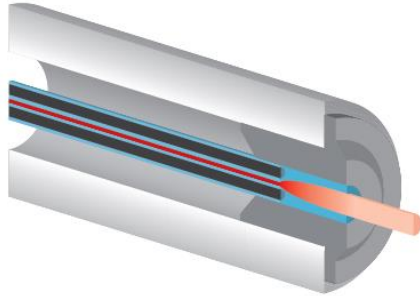

- High power laser applications using PM fibers are increasing. Diamond offers optical interfaces that support polarization maintaining (PM) fibers and higher optical power densities (PS).

- Applications:

- Lidar
- Optical fiber lasers and amplifiers
- Sensing

- FEATURES AND BENEFITS

- Low Insertion loss due to ACA
- Ultra high polish for High return loss
- Improved power resistance (x16)
- Extremely low angular offset
- High Extinction Ratio due to APO

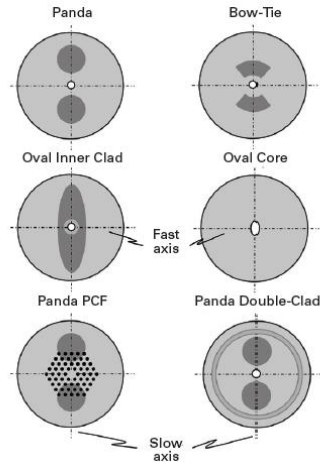

Specifications for **PM-PS** version



STANDARD PERFORMANCES

WAVELENGTH (nm)	Angular Error ϕ	IL (dB)		PER (dB)		RL (dB)	
		Typ	97% (TBC)	Typ	Min (TBC)	PC 0°	APC 8°
1625 - 1550 - 1310 1060 - 980		1 1	0.8 1.5	24 23	21 20	45* 35	70* 60*
TEST CONDITIONS		IEC 61300-3-34 Random mating		IEC 61300-3-40 Low coherence		IEC 61300-3-6 *OLCR method <OCWR method **Limited by test conditions	
Lifetime	500 mate/demate cycles						

- Optical values based upon high-quality Panda and Bow-Tie fibers qualified by Diamond (fiber's NA 0.12 ± 0.02).
- Performances based upon E-2000™ optical interfaces; other mechanical interfaces may lead to slightly different results. Please contact Diamond for details.
- Diamond performs PER measurements according to the crossed-polarizer method (similar to IEC 61300-3-40) that relies upon high-extinction Glan-Thomson polarizers and incoherent light sources (bandwidth > 10 nm).
- For any other requirement, please contact Diamond.

DMI Power Solution multimode (PSm) version



The technology

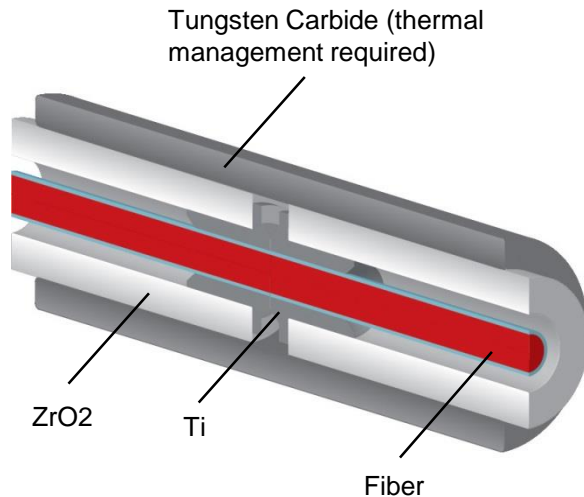

- The use of multimode fiber to transport high power applications in the laser industry is also on the rise. Connectors are slowly being integrated where a required modularity feature is preventing the use of a splice.

■ BENEFITS

- ➔ Resistant to high power
- ➔ Low Insertion loss due to ACA
- ➔ Easy thermal management

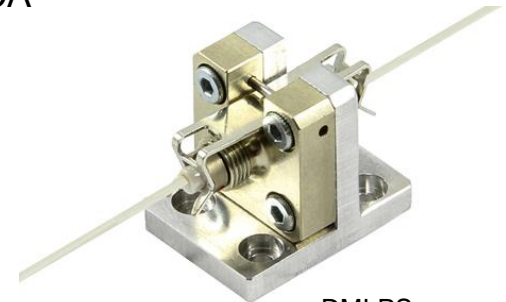

DMI PSm

DMI Power Solution multimode (PSm) version



PERFORMANCES

	MM100 PC 0°	UNITS	TEST CONDITIONS
Numerical Aperture, NA	0.22		
Core	105	microns	
Cladding	125	microns	
Insertion loss (IL) (random)	≤ 0.4 (0.1 typ)	dB	IEC 61300-3-4*
Return Loss (RL) (in contact)	40	dB	IEC 61300-3-6, at 1300/1550nm
Return Loss (RL) (no contact)	15	dB	
Max Power density**	0.3	MW/cm ²	
Max Power***	100	W	As tested in laboratory
Service life	500	mate/demate	According to field experience
Visual Inspection	Diamond		
Operating temperature	-25 / 70****	°C	
Storage temperature	-25 / 85	°C	

* With launch condition from light source using mode conditioning patchcord and 750m of 100/140fiber

** 2 micron particles burn limit (limit based on glass melting temperature)

*** Limit based on modeling and laboratory testing

**** Requires cooling (lower than 30°) of the mating adapter basement

System Integration and Flexibility

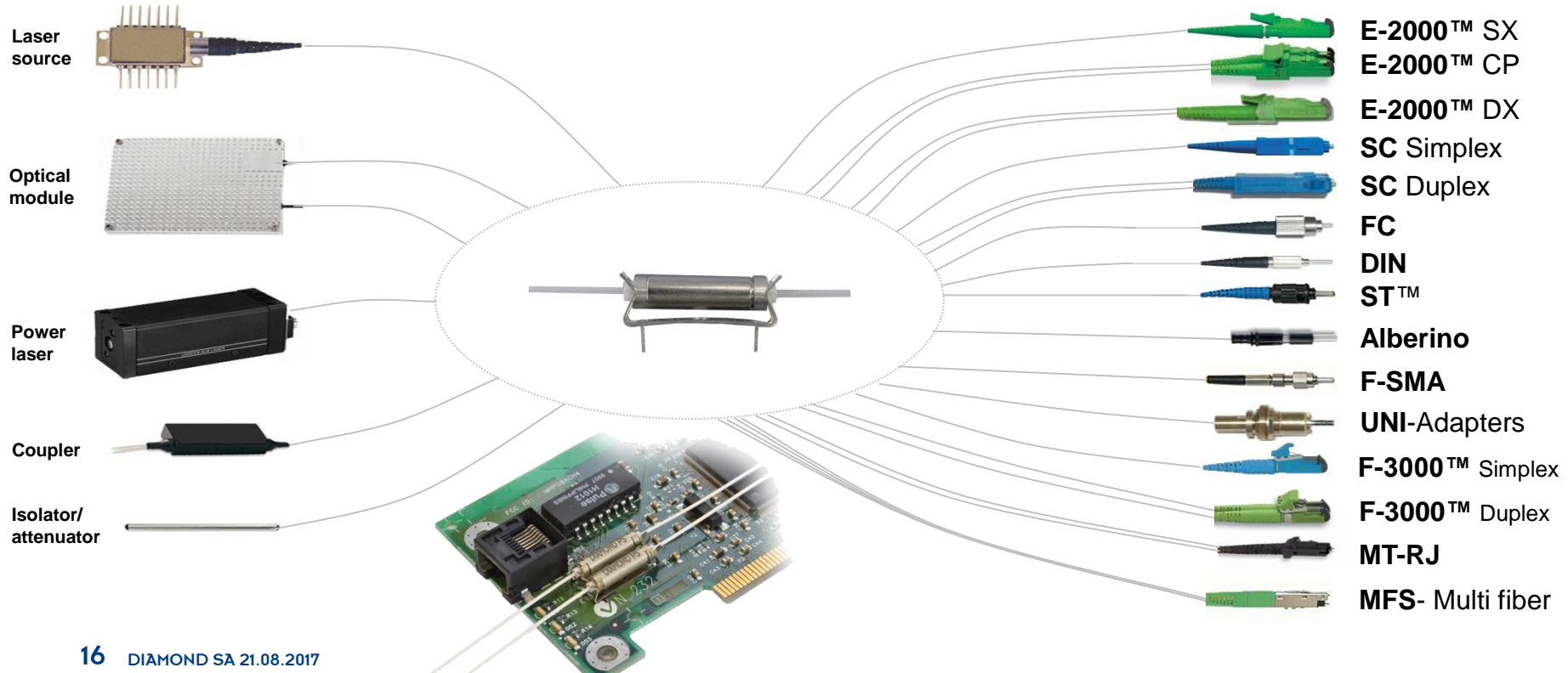

DMI Mounting tool and instructions



■ Fixing DMI assembling onto the clip:

- 1) Position one lateral side of DMI assembly into the clip (be sure that the V-Groove of DMI connector is correct (see detail))
- 2) Position the DMI on the other side of DMI assembly and press down on DMI clip

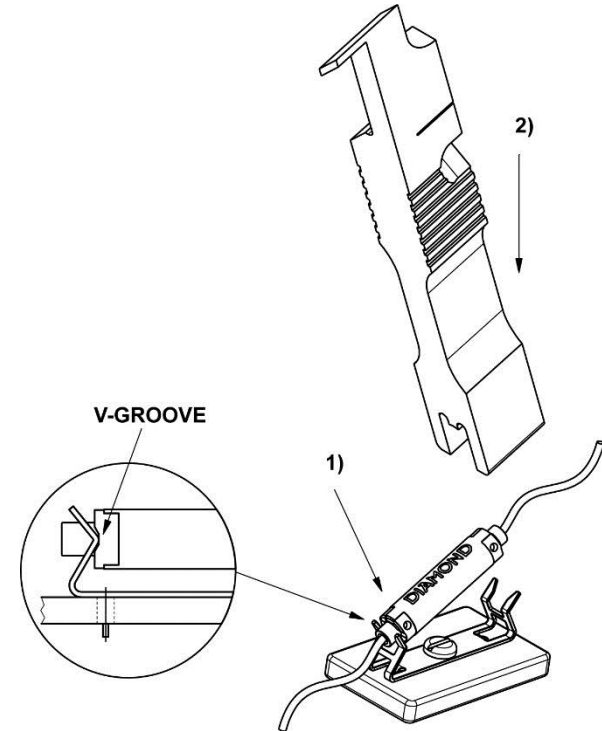

DMI Mounting tool and instructions



■ Releasing DMI assembly from the clip:

- 1) Position DMI tool between DMI assembly and clip
- 2) Push the DMI tool down to release the DMI assembly

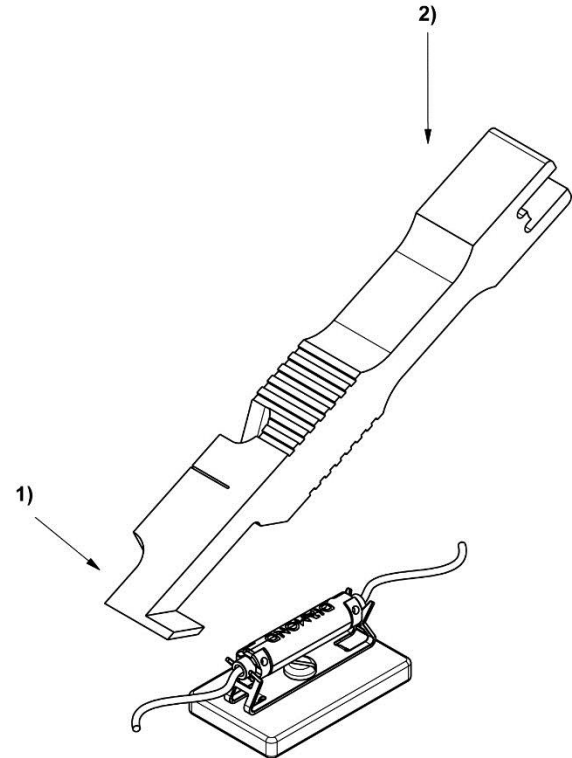

DMI Mounting tool and instructions



■ Uncoupling of DMI connector from mating adapter:

1) Position DMI assembly on DMI tool.

(Be sure that the blade of DMI tool is positioned between DMI adapter and connector)

2) Pull the DMI assembly to uncouple connector from adapter

